

MFJ-1700B Instruction Manual

Thank you for purchasing the MFJ TRANSMITTER-ANTENNA SWITCH. The MFJ-1700B is a heavy duty switch which allows you to connect any one of 6 transceivers in any combination. The MFJ-TRANSMITTER-ANTENNA SWITCH handles up to 2 KW PEP for 50-75 ohm loads. As shown in the diagram, an antenna tuner, SWR/Wattmeter, linear, e.t.c., can plug in between the transceiver(s) and antennas so that they are always in the circuit. All unused inputs and outputs are shorted to ground.

To use, simply connect the transmitter(s) you want to use to lettered coax connector(s) on the bottom of the unit. Connect the antenna(s) you want to use to the numbered coax connector(s) on the top of the unit. Connect an antenna tuner, SWR/Wattmeter, e.t.c., to the ANT COM and XMIT COM connectors on the top and bottom of the unit. Select with the switches, on the front panel of the front panel of the MFJ-1700B, the desired transmitter and antennas.

If using only one antenna in combination with more than one transmitter, or one transmitter in combination with more than one antenna, the MFJ-1700B can be used to tie them together by using one side of the coax connectors in the following sequence:

- Transmitter COM ties to A-F
- Antenna COM ties to 1-6

Also following these connections, the MFJ-1700B can be used as two independent switches.

If using the MFJ-1700B with more than one transmitter and more than one antenna without antenna tuner, SWR/Wattmeter, e.t.c., simply connect the Antenna COM to the Transmitter COM with a coax cable, preferably as short as possible.

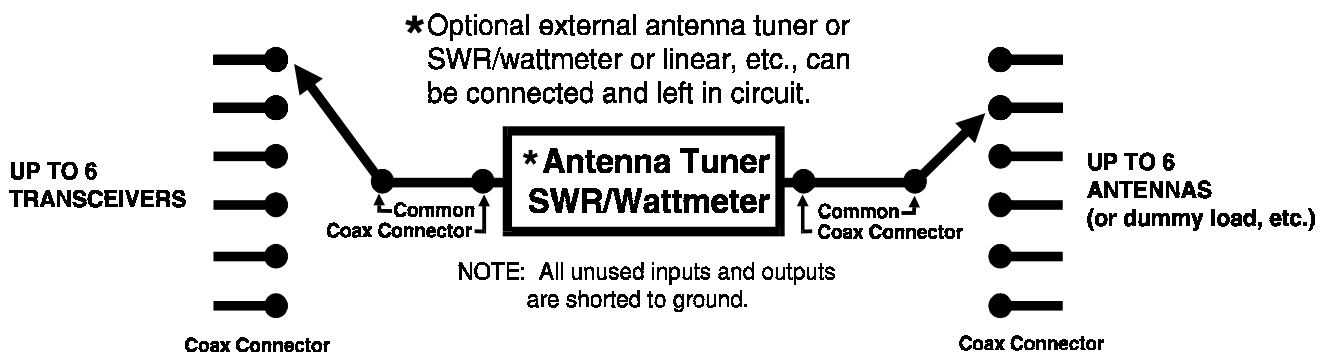

CONNECT ANY TRANSCEIVER TO ANY ANTENNA.